



Loaded with powerful features

Strength, durability, and performance are at the core of the newly refined Encore by Wascomat small chassis front load dryer. Built with professional grade components and loaded with powerful features, Encore combines innovative technology, energy efficiency, and proven Wascomat reliability for optimal results every time.

Encore Dryer Key Features

- Commercial grade construction
- Extra large load drum — 22+ pound capacity
- 7.0 cu. ft. drum
- Drum supported by five roller bearings for long life
- Fast drying
- Axial airflow ensures the shortest drying time
- Roller supported tumbler
- Easy to clean, heavy duty lint screen
- Extra large door opening for easy loading and unloading
- Large capacity can handle oversized loads with ease
- Space-saving design
- Easy to install
- Stacking kit available



Proposition 65 Compliant

ADA Compliant

Available in Electric and Gas.

Encore Dryer Specifications at a Glance

Dry Capacity	22 lb / 10 kg
Cylinder Volume	7.7 cu ft / 218 liters
A. Overall Height	42 1/2 in (1080 mm)
B. Height to Center of Door	23 in (584 mm)
C. Height to Bottom of Door	12 in (305 mm)
D. Overall Width	27 in (686 mm)
E. Overall Depth	29 in (737 mm)
F. Depth w/ Door Open 90°	51 1/2 in (1308 mm)

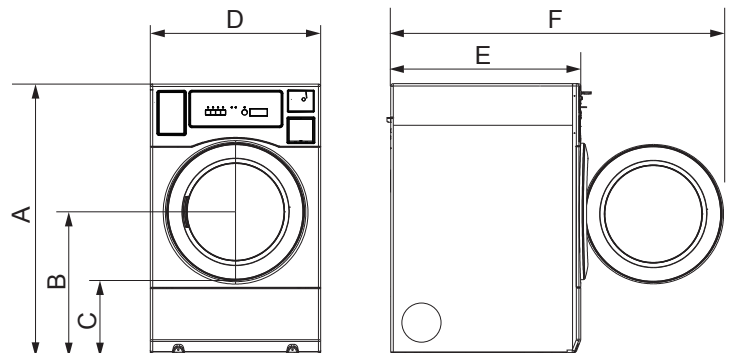

Specifications subject to change without notice.

Encore by Wascomat Dryer Specifications

Motor	1/3 HP
Electrical Rating (Gas Model)	120 V/60 Hz / 1-phase
Electrical Rating (Electric Model)	120 V/240/60 Hz/1-phase or 120 V/208/60 Hz/1-phase
Breaker Fuse Requirements (Gas Heat)	15A
Breaker Fuse Requirements (Electric Heat)	30A
Cylinder Volume	7.7 cu ft (218 liters)
Cylinder Diameter	26 in (660 mm)
Cylinder Depth	20.8 in (528 mm)
Capacity (Dry Weight)	22 lbs (10 kg)
Airflow	192 cfm
Gas Heating	19,000 BTU/hr
Electric Heating	5.0 kW
Gas Connection	3/8 in MNPT
Tumbling Speed	50 rpm
Exhaust Connection	4 in diameter
Approx. Net Weight	158 lbs (71.7 kg)
Approx. Shipping Weight	173 lbs (78.5 kg)

Product Dimensions

A. Overall Height	42 1/2 in (1080 mm)
B. Height to Center of Door	23 in (584 mm)
C. Height to Bottom of Door	12 in (305 mm)
D. Overall Width	27 in (686 mm)
E. Overall Depth	29 in (737 mm)
F. Depth w/ Door Open 90°	51 1/2 in (1308 mm)

Refer installation and servicing to qualified, licensed personnel. Always read Installation and Operating Manuals and consult local codes before installation. Protect machines with properly rated circuit breakers ONLY. Warranty void if not properly installed.

Specifications subject to change without notice. Wascomat assumes no responsibility for errors or omissions in this information.



Axial Airflow

The highly efficient axial airflow system and tight construction results in extremely low energy usage and faster dry times.



Roller Supported Tumbler

Innovative support rollers improve drum stability, ensure quiet operation, and extend the life of the machine.

Encore Dryer Product Dimensions

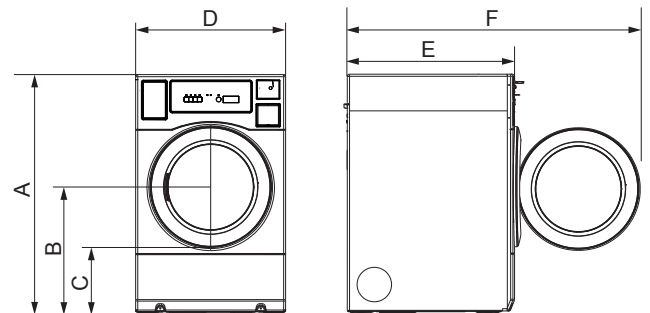

ENCORE
by **Wascomat**

Ontario
Laundry Systems Inc.

Proudly Canadian. Family owned and operated since 1995.

7475 Kimbel St, Unit 5 • Mississauga, ON L5S 1E7
905-673-1308 • info@ontariolaundry.com • ontariolaundry.com