

# ENCORE

PRO

## TOP LOAD WASHER

## Real Choice Better Solutions

Finally, a top load washer engineered for multi-housing providers.

### SMART DESIGN FOR A BETTER EXPERIENCE

- Large Capacity for Families and Bulky Items
- Superior Cleaning Performance
- 4 Cycle Options: Cold, Warm, Hot, and Delicate
- Separate Controls for Heavy Soil and Extra Rinse
- Quicker Drying Time Due to a Fast 745 RPM Spin

Built with professional-grade components, outweighing the competition and backed by the best 5-year parts warranty.

### SIGNATURE PRO FEATURES

- 2.9 cu. ft. Capacity
- 155 G-Force Extraction
- Direct Drive Motor
- Onboard Self Diagnostics
- Pro Smart Accelerometer
- Quieter Operation
- Sharp LED Display
- No Lid Lock
- 4 Wash Cycles
- Add Revenue with Heavy Soil and Extra Rinse Options
- Easy Adjustable Legs
- Durable 3-Layer Paint Application
- Coin and Card Compatibility
- 5-Year Parts Warranty



### ULTRA CONVENIENT NON LOCKING LID

Safely add or remove items at any point in the cycle.



### SIMPLE SELECT CONTROL

Eliminate error with intuitive controls and wash options.



### EASY ACCESS REPAIR PANEL

90% serviceability from the front of the machine.



### PRO GRADE OUTER TUB

Greater durability for years of superior performance.

| SPECIFICATIONS                     |  |
|------------------------------------|--|
| Model                              | WMTW4371C2FMI (coin)<br>WMTW4371C2DC (card)<br>WMTW4371C2OPL (OPL) |
| Capacity – lb (kg)                 | 18 lb (8 kg)   |
| Cylinder Volume – cu. ft. (liters) | 2.9 cu. ft. (82 l)   |
| Wash Cycles & Options              | Cold, Warm, Hot, Delicate, Heavy Soil, Extra Rinse                 |
| Motor                              | 0.34 HP (0.25 kW)  |
| Electrical Rating – v/Hz/Ph        | 120 V/60 hz/1-phase  |
| Breaker Requirements – Amps        | 15 A   |
| Wash Speed – RPM                   | 745 RPM (maximum)  |
| Maximum G-force                    | 155 G  |
| Inlet Hose – in                    | 2x 3/8 in (hoses included)   |
| Water Pressure – Psi (kPa)         | 8-145 psi (50 -1000 kPa)   |
| Drain Hose – in (mm)               | 0.94 in (24 mm)  |
| Crated Weight – lb (kg)            | 163 lb (74 kg)   |
| Uncrated Weight – lb (kg)          | 137 lb (62 kg)   |

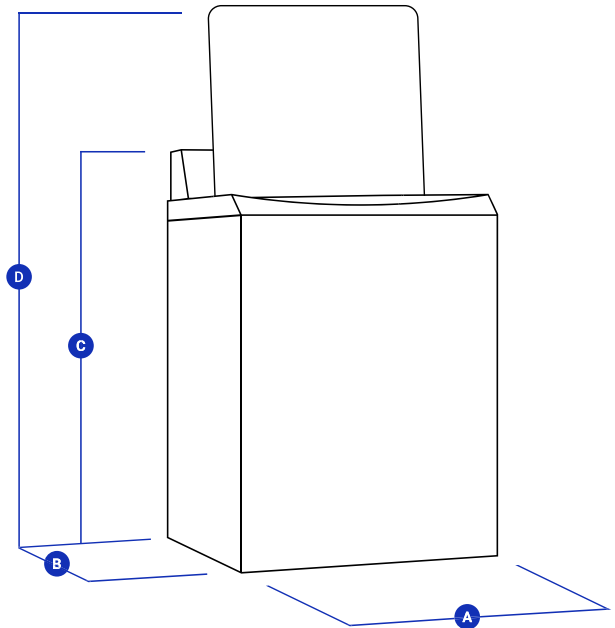

| EQUIPMENT DIMENSIONS            |                       |
|---------------------------------|-----------------------|
| A. Overall Width – in (mm)      | 27 in (686 mm)        |
| B. Overall Depth – in (mm)      | 27 in (686 mm)        |
| C. Overall Height – in (mm)     | 44 21/64 in (1126 mm) |
| D. Height with Lid Up – in (mm) | 52 61/64 in (1345 mm) |

### COMPLIMENTARY PRODUCTS

#### Gas Dryer

DLHF0315GC2 (coin)  
DLHF0315GC2DC (card)  
DLHF0315GC2OPL (OPL)

#### Electric Dryer

DLHF0315EC2 (coin)  
DLHF0315EC2DC (card)  
DLHF0315EC2OPL (OPL)

Actual color may vary. Dimensions are for planning purposes only.

Refer installation and servicing to qualified, licensed personnel. Always read Installation and Operating Manuals and consult local codes before installation. Protect machines with properly rated circuit breakers ONLY. Warranty void if not properly installed.

Because of continuous product improvement, specifications are subject to change without notice. Laundrylux assumes no responsibility for errors or omissions in this information.

